

Specifications

SMART Board™ Interactive Whiteboard System

Model SBD685i3

Physical Specifications

SMART Board™ 685 Interactive Whiteboard

Size	77 1/2" W × 50 5/8" H × 5 1/8" D (196.9 cm × 128.6 cm × 13 cm)
Active Screen Area (maximum interactive, projected image)	74" W × 46 1/8" H (188 cm × 117.2 cm) 87 1/8" (221.3 cm) diagonal, 16:10 aspect ratio
Weight	42 lb. (19.1 kg)
Shipping Size	54" W × 86 1/4" H × 5 1/2" D (137.2 cm × 219.1 cm × 14 cm)
Shipping Weight	72 lb. (32.7 kg)

UF55w Projector System

Total Size	18 1/2" W × 15 1/2" H × 50 1/4" D (47 cm × 39.4 cm × 127.6 cm)
Remote Control	1 5/8" W × 3 3/8" H × 1/4" D (4 cm × 8.6 cm × 0.7 cm)
Extended Control Panel	11" W × 7 5/8" H × 2 3/8" D (27.9 cm × 19.4 cm × 6 cm)
Weight	33 lb. 14 oz. (15.4 kg)
Shipping Size	
Accessory Box	39 3/4" W × 9 1/2" H × 16" D (100.9 cm × 24.1 cm × 41.2 cm)
Projector Box	18 1/2" W × 15 1/8" H × 8 1/4" D (47 cm × 38.5 cm × 21 cm)
Shipping Weight	41 lb. 3 oz. (18.7 kg)

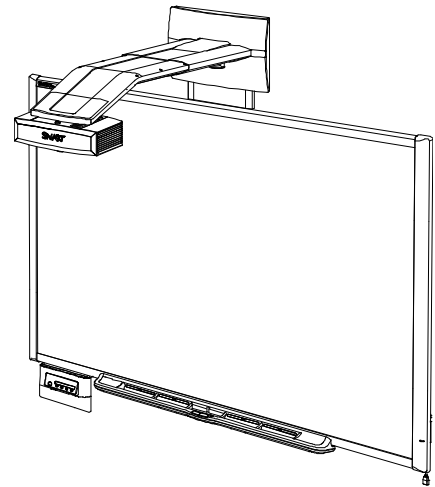

All dimensions +/- 1/8" (0.3 cm). All weights +/- 2 lb. (0.9 kg).

Standard Features

Software	Includes SMART Notebook software. See the SMART Notebook software specifications for a complete list of system requirements. Software upgrades are available from www2.smarttech.com/st/en-US/Support/SBS/ .
Certifications and Compliance	CSA (U.S./Canada), CB, CE, FCC, China EIP, RoHS (Europe), WEEE, VCCI (Japan) and C-Tick (Australia)
Warranty	The projector and extended control panel (ECP) have a three-year limited equipment warranty. The UF55w projector lamp has a 500 hour/90 day warranty. Your interactive whiteboard has a two-year limited equipment warranty or a five-year limited equipment warranty upon registration. See included warranty documents for details.
Cables	Includes the necessary cables to connect the projector to the ECP. However, you must supply the appropriate input cables for your additional computers and devices.

Interactive Whiteboard Features

Dual Touch/Dual Write	Enables two users to work simultaneously in SMART Notebook software
Pen Tray	Optical sensors in the pen tray detect when you lift one or two pens, or the eraser, from the tray. LEDs indicate the active tools.
Pens and Eraser	Black, red, green and blue pen tray pens and a rectangular eraser
Resolution	Touch resolution is approximately 4000 × 4000.
Screen Surface	The hard-coated surface is tear proof, optimized for projection, compatible with dry-erase markers and cleans easily with whiteboard cleaner.
Digitizing Technology	Resistive technology
Frame Finish	Dark gray (approximates Pantone® Charcoal Gray 18-0601 TPX) and Ultrasonic Chrome (approximates metallic Pantone 877C)
Wall-Mount Bracket	Includes two 32" (81.3 cm) wide brackets, ten screws and ten drywall anchors to support your wall-mounted interactive whiteboard
Projector Mounting Template	This template ensures simple installation and accurate alignment between the UF55w projector and your SMART Board SBD685 interactive whiteboard.
Installation Instructions	Don't use the installation instructions included in your SMART Board interactive whiteboard box when installing your SMART Board SBD685i3 interactive whiteboard system. The installation instructions for your SMART Board SBD685i3 interactive whiteboard system are included with the UF55w projector.
Theft Prevention	Features a pen tray locking feature and a Kensington® security slot on the pen tray

UF55w Projector System Features

System Components	UF55w projector, boom mount with a limit strap (including a controlled-collapse feature), ECP, remote control and all necessary input cables from the ECP to the projector
Image Adjustment	The mounting boom includes three mechanical adjustments for aligning the projector image with your interactive whiteboard. The projector also has a focus lever and a digital on-screen menu for brightness, contrast and other image-related attributes.
Display Type	WXGA 1280 × 800 projector
Display Technology	The projection engine uses DLP® technology by Texas Instruments™, providing BrilliantColor™ performance and quality Gamma 2.2 correction with Bright Classroom, Dark Classroom, sRGB and User modes.
Brightness	Estimated at 2000 lumens (typical) at a CCT of 6500 K by the IEC method
Lamp Life	3000 hours (Standard 200 W mode) or 4000 hours (Economy 160 W mode)
Aspect Ratio	Support for 16:9, 16:10 and 4:5 ratios
Contrast Ratio	2000:1
Video System Compatibility	NTSC, NTSC 4.43, PAL, PAL-N, PAL-M and SECAM
Video Interface Compatibility	Composite, S-video, and VESA RGB, with additional interface support for Component YPbPr and Component YCbCR inputs with the proper adapters (not included)
Video Format Compatibility	Native 16:10 aspect ratio XGA projector resolution. With scaling, supports VGA, SVGA, SXGA, QuadVGA, SXGA+ and UXGA formats.
Synchronization	Auto image synchronization (auto tracking, frequency, position adjustment, source detect and phase detect)
Mounting Hardware	Includes hardware for mounting the UF55w projector and the ECP to framed and solid walls. Includes a safety tether and limit strap.
Input/Output Connections	<ul style="list-style-type: none">• Two HD DB15F connectors – RGB video input from your computer and/or ECP via VGA connectors• HD DB15F connector – video output pass-through of Video Input 1 signal• 4-pin mini-DIN connector – S-video input• One pair of audio jacks (RCA, stereo) – reserved for use with S-video• Composite video connector – RCA-style video input• One pair of audio jacks (RCA, stereo) – reserved for use with composite video• 3.5 mm stereo jack – audio input from your computer• 3.5 mm stereo jack – audio output to connect speakers• DB9M – serial (RS-232) for power to and communication with the ECP• RJ-45 – network connection for SNMP management and control, and for sending e-mail alerts

Projector Fan	<ul style="list-style-type: none">• Standard speed – 0 to 6000' (0 m to 1829 m): 41°F to 95°F (5°C to 35°C)• High speed – 6000' to 6800' (1829 m to 2073 m): 41°F to 86°F (5°C to 30°C)
Projector Noise	36 dBA (high fan speed) or 31dBA (standard fan speed), measured using JIS method
Power Requirements	100V AC to 240V AC, at 50 Hz to 60 Hz
Power Switch	Master power control switch
Power Cable	Includes a 14' 9" (4.5 m) power cable
External Control	The RS-232 connector is configured to accept control codes from your computer or a room control system.
Power Consumption	385 W (Standard mode) to 504 W maximum. 5 W in Standby mode.
Remote Control	Provides an alternative method of controlling the UF55w projector settings
Theft Protection	The UF55w projector system features optional security screws on the projector plate and an optional padlocked ring to safeguard the adjustment knob. The projector won't function if it's separated from the ECP and can't be operated without the remote control. A Kensington security lock slot is provided to affix the system to a wall as a visual and physical theft deterrent.

ECP Features

Input/Output Connections	<ul style="list-style-type: none">• HD DB15F connector – RGB video from your computer (supports component video CAV, YPbPr or YUV)• HD DB15F connector – RGB video to the projector• DB9F – serial (RS-232) computer or room control connection• DB25M – provides input signals and control signals to the projector• 4-pin mini-DIN connector – S-video input• One pair of audio jacks (RCA, stereo) – reserved for S-video• Composite video connector – RCA-style video input• One pair of audio jacks (RCA, stereo) – reserved for composite video• 3.5 mm stereo jack – computer audio input
Power Button	Turns the projector on and off
Input Selection Buttons	Provide control for the following input types: <ul style="list-style-type: none">• S-video and associated audio (RCA jacks)• Composite video and associated audio (RCA jacks)• Computer 2 VGA input and associated 3.5 mm audio stereo jack

Storage and Operating Specifications

- Storage**
- Maximum storage temperature: 122°F (50°C)
 - Minimum storage temperature: -40°F (-40°C)
- Operation**
- Using standard fan speed, 41°F to 95°F (5°C to 35°C) from sea level to an altitude up to 6000' (0 m to 1829 m)
 - Using high fan speed, 41°F to 86°F (5°C to 30°C) from 6000' to 6800' (1829 m to 2073 m)
 - In Service mode, 41°F to 86°F (5°C to 30°C) from 6800' to 9800' (2073 m to 2987 m)

SMART Order Numbers

- SBD685i3** 87 1/8" (221.3 cm) diagonal dual-touch SMART Board 685 interactive whiteboard with a UF55w projector
- 20-01032-20** Replacement projector lamp

Optional Accessories

 NOTE

The RS-232 to USB conversion module and WC6 wireless Bluetooth® connection option aren't available for this model of SMART Board interactive whiteboard.

- RPEN-ER** Replacement set of four pen tray pens (black, red, green and blue) and a rectangular eraser
- RPEN** Replacement set of four pen tray pens (black, red, green and blue)
- SBA** USB audio system for SMART Board SBD600i interactive whiteboard systems

Physical Dimensions

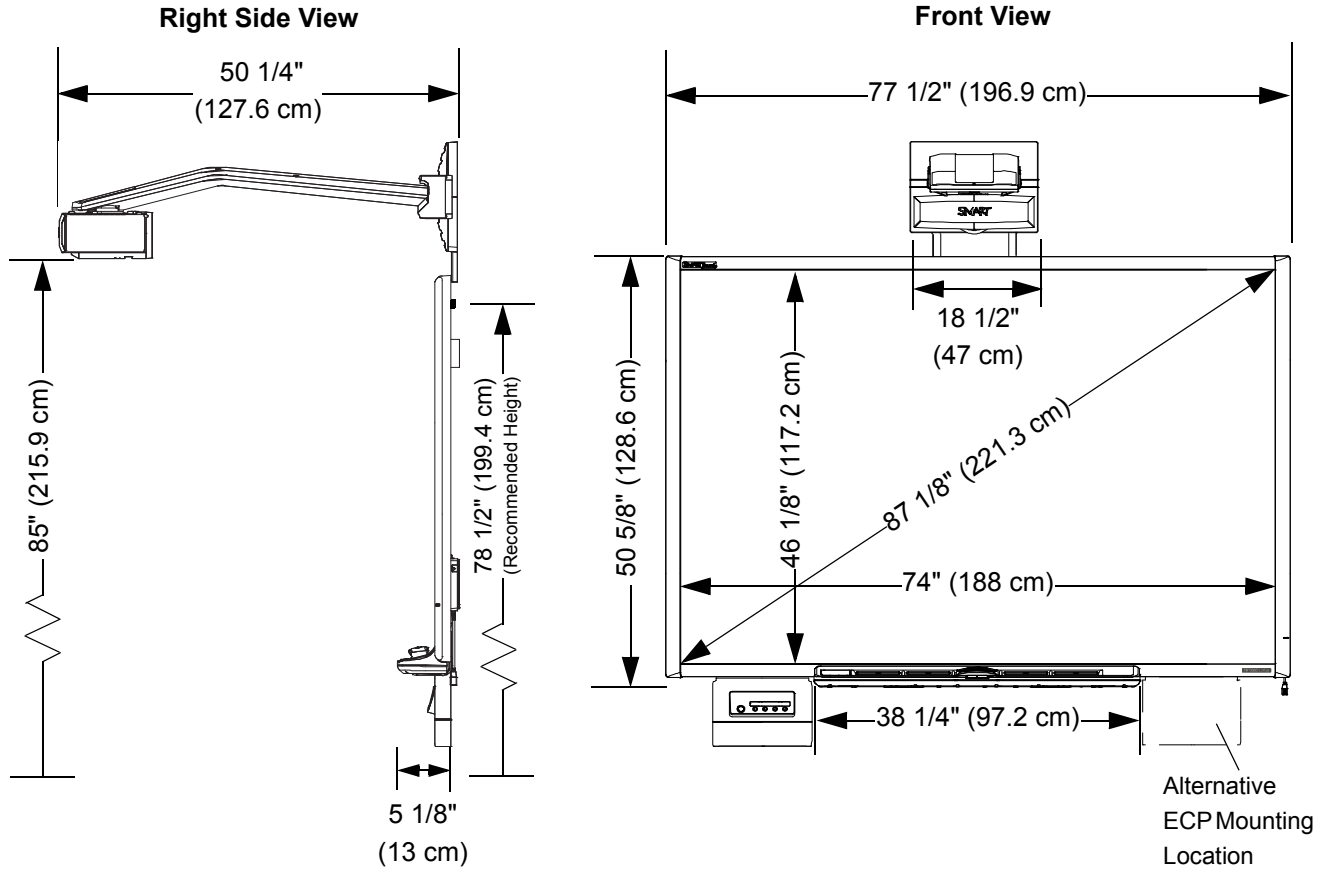

ECP Right Side View

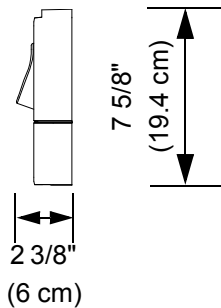

ECP Front View

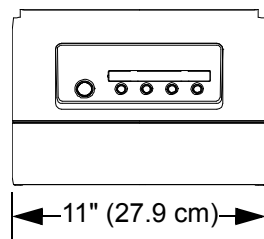

Projector Mounting Bracket

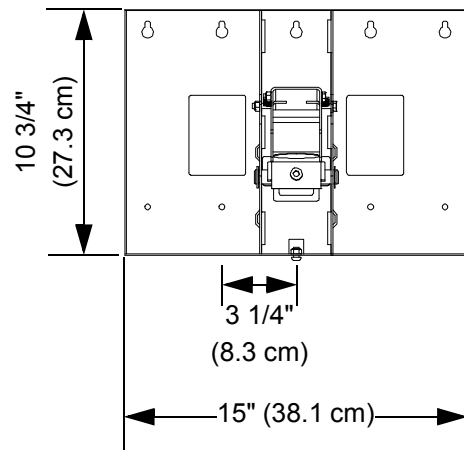

www.smarttech.com/support www.smarttech.com/contactsupport
Support +1.403.228.5940 or Toll Free 1.866.518.6791 (U.S./Canada)

