

# In-Wall *Rear Projection* SMART Board™ Interactive Whiteboard

## Specifications – Model 2976

### Physical Specifications

<b>Size</b>	72 1/4" W x 55 1/4" H x 2 5/8" D (183.5 cm x 140.3 cm x 6.7 cm)
Interactive Whiteboard	
Pen Tray with Keyboard Bracket	38 1/4" W x 9 5/8" H x 4 5/8" D (97.2 cm x 24.4 cm x 11.8 cm)
Active Screen Area	67 1/4" W x 50 3/8" H (170.8 cm x 128.0 cm) 84" (213.4 cm) diagonal
<b>Installation Information</b>	68 5/8" W x 54 3/8" H (174.3 cm x 138.1 cm) The interactive whiteboard must be mounted between two studs that run from floor to ceiling.

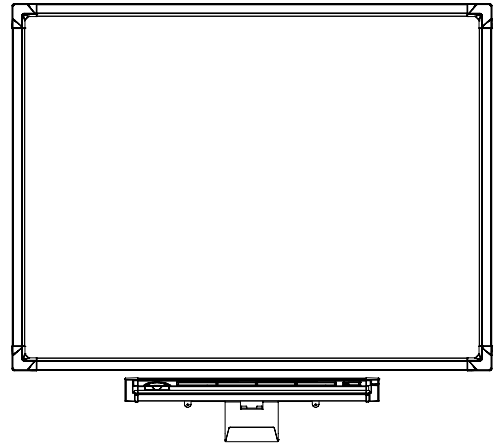

**NOTE:** Allow at least 15" (38.1 cm) between the lower cabinet of the mirror stand and the wall surface upon which the interactive whiteboard is mounted.

<b>Weight</b>	Interactive Whiteboard	105 lb. (47.6 kg)
	Mirror Stand (with Projector)	225 lb. (102.1 kg)
<b>Shipping Weight</b>	Crate 1 (Interactive Whiteboard)	160 lb. (72.6 kg)
	Crate 2 (Mirror Stand)	408 lb. (185.1 kg)
<b>Shipping Size</b>	Crate 1 (Interactive Whiteboard)	77" W x 65" H x 26" D (195.6 cm x 165.1 cm x 66.0 cm)
	Crate 2 (Mirror Stand)	62" W x 88" H x 43" D (157.5 cm x 223.5 cm x 109.2 cm)

All dimensions +/- 1/8" (3.2 mm). All weights +/- 2 lb. (0.9 kg).

### Standard Features

<b>Software</b>	SMART Board software and Notebook™ software. Free software upgrades are available at <a href="http://www.smarttech.com/support/software/index.asp">www.smarttech.com/support/software/index.asp</a> .
<b>SMART Mirror Stand</b>	Fully assembled with adjustable feet for height control. Includes projector with short-throw lens.
<b>Pen Tray</b>	Optical sensors in the pen tray detect when a pen or the eraser is lifted from the tray. LED indicators show the active tool. Includes four pens (black, blue, red and green) and one eraser.
<b>Keyboard Bracket</b>	Bracket attaches to the wall below the pen tray to hold the wireless keyboard and IR receiver
<b>Wireless Keyboard</b>	US English Windows® operating system with built-in trackball (all regions except Japan)
<b>Resolution</b>	Touch resolution approximately 2000 x 2000. Supports all projector resolutions up to 1600 x 1200.
<b>SMART Super Screen</b>	Bright image with uniform light distribution. Suitable for high ambient lighting, specifically meeting rooms or videoconferencing rooms.
<b>Screen Surface Material</b>	Extremely durable, low-reflection (matte) finish reduces glare from overhead lights
<b>Digitizing Technology</b>	DViT™ (Digital Vision Touch) technology uses digital cameras to track an object interacting with the display surface
<b>Computer Connection</b>	A 21' 6" (6.6 m) SMART USB adapter cable is included
<b>Power Supply</b>	A switching power supply, 100V–250V AC, 47 Hz–63 Hz, 12V DC 4.2A, with a 6' (1.8 m) country-specific power cord
<b>Power Requirements</b>	Approximately 500 watts. This 500-watt estimate does not include the internal computer or other optional components, such as a VCR or DVD player.

## Specifications – Model 2976

**Warranty** Two-year limited equipment warranty on the screen, cabinet and projector. 500 hour/three month warranty on the projector lamp.

---

### Projector

**Display Type** True XGA (1024 × 768) NEC VT676 projector with short-throw lens

**Display Technology** 0.7" p-Si TFT with MLA

**Contrast Ratio** 400:1

**Lamp (Life)** 200 W, 2000-hour lamp life (user changeable)

**Scanning Rates** H-sync 15 kHz–100 kHz; V-sync 50 Hz–120 Hz

**Video Compatibility** NTSC, NTSC 4.43, PAL, PAL-60, PAL-M, PAL-N, SECAM

**Projector Support** Replacement projector shipped within one business day. Upon request, original projector repaired and returned within five business days. Available free of charge for two years.

---

### Storage and Operating Specifications

**Storage** -40°F to 95°F (-40°C to 35°C) with up to 95% humidity non-condensing

**Operation** 41°F to 95°F (5°C to 35°C) with up to 90% humidity non-condensing

---

### SMART Board Software 9.5 Computer Requirements

**Windows Computers** Pentium® II 450 MHz processor  
128 MB of RAM (256 MB recommended)  
136 MB of free hard disk space for minimum installation (511 MB for full installation with Gallery collections)  
Windows NT® 4.0 (SP6), Windows 98 operating system or later  
Microsoft Internet Explorer® 6.0 or later  
Macromedia® Flash® player version 8

**NOTE:** The AirLiner™ wireless slate requires the Windows 2000 or Windows XP operating system.

**Requirements for SMART Video Player** Pentium II 450 MHz processor (700 MHz or faster recommended)  
Windows 98 operating system or later. Does not run on the Windows NT operating system.  
Microsoft® DirectX® technology 8.1 or later

**Mac Computers** 700 MHz processor (1 GHz or faster recommended)  
128 MB of RAM (256 MB recommended)  
Mac OS X versions 10.3.9 and 10.4.x  
148 MB of free hard disk space for minimum installation (423 MB for full installation with Gallery collections)  
Safari™ 1.3.2 or later  
SMART Board software version 9.5 supports Intel® processors (Universal Binary)

**NOTE:** Previous versions of SMART Board software are compatible with earlier versions of the Mac OS X operating system. To download a previous version of SMART Board software, go to [www.smarttech.com/support/software/sb\\_mac\\_other.asp](http://www.smarttech.com/support/software/sb_mac_other.asp).

### Linux® Computers

Pentium II 450 MHz processor  
128 MB of RAM (256 MB recommended)  
185 MB of free hard disk space for minimum installation (460 MB for full installation with Gallery collections)  
Linux kernel version 2.6 or later  
X Windows version 11 release 6 (X11R6) or later (must support XRENDER and Xinerama)  
glibc 2.3.3 (gcc 3.4.2)  
libstdc++6  
Gnome 2.8.0+ or KDE® 3.3+ libraries (recommended)  
SUSE® 10, Red Hat® Enterprise Linux 4 WS, Fedora™ Core 3, Debian™ 3.1 (Sarge) or Ubuntu 6.06 LTS

Front and Side Views

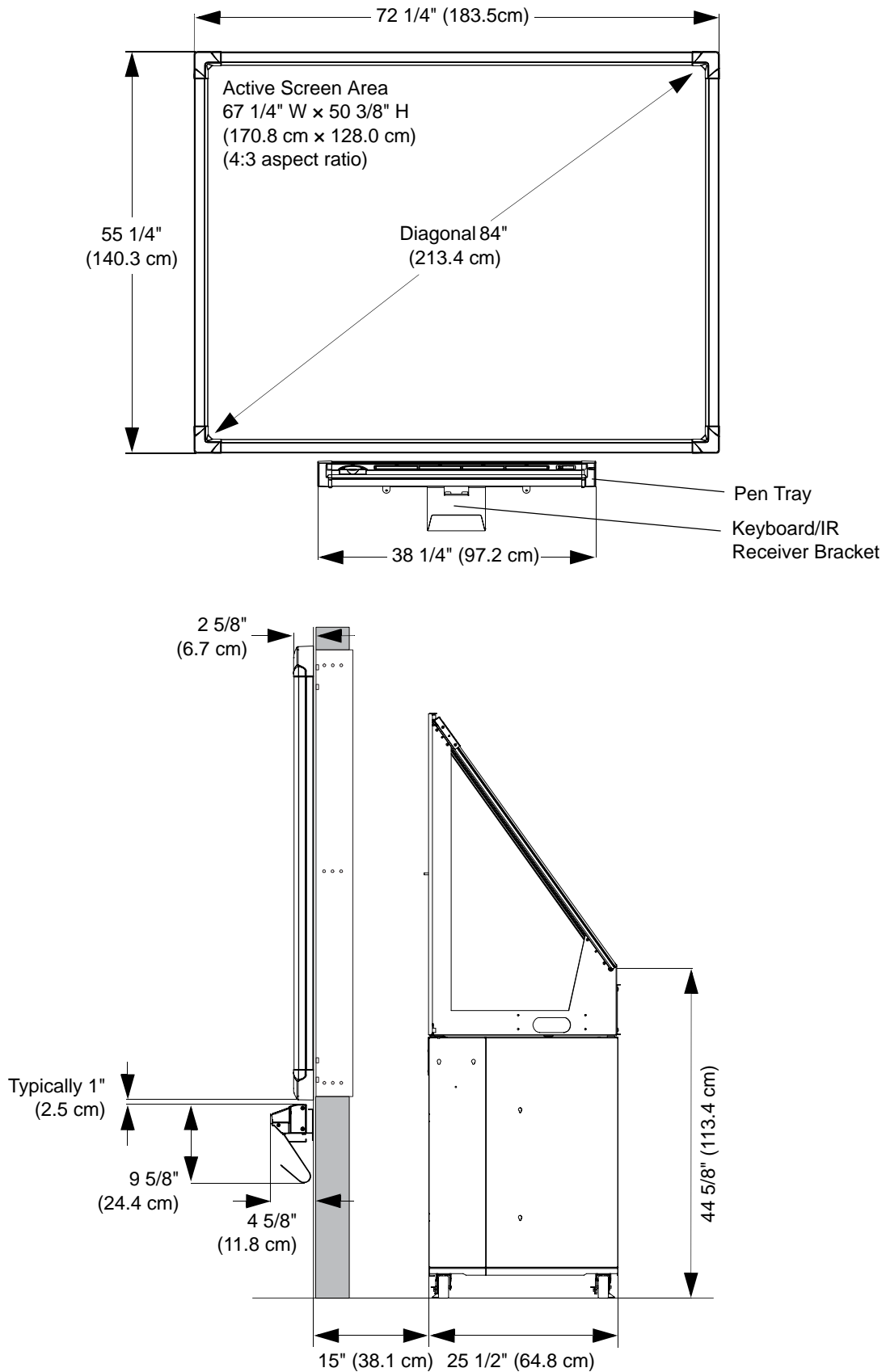

Mirror Stand

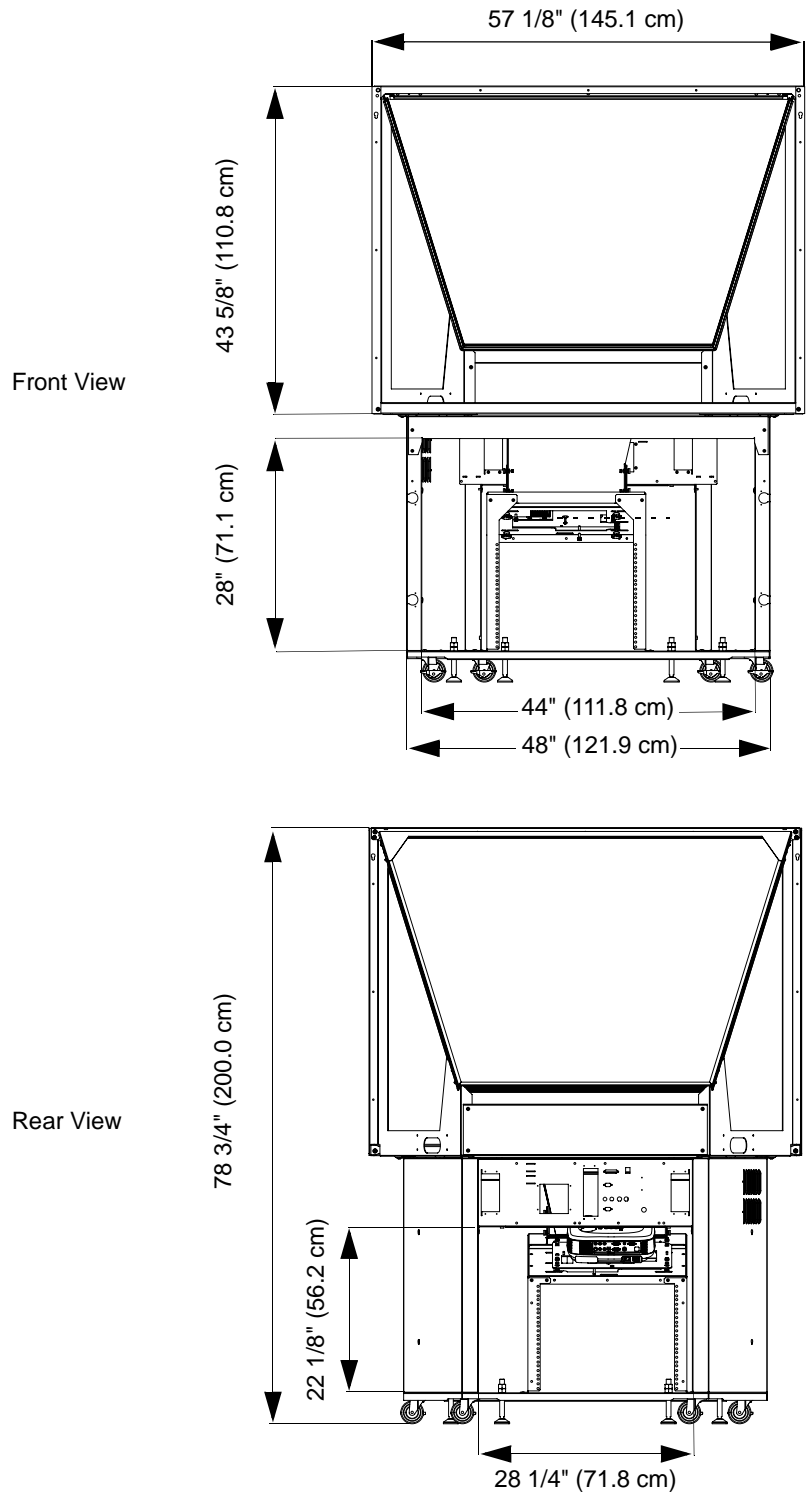

Wall Opening

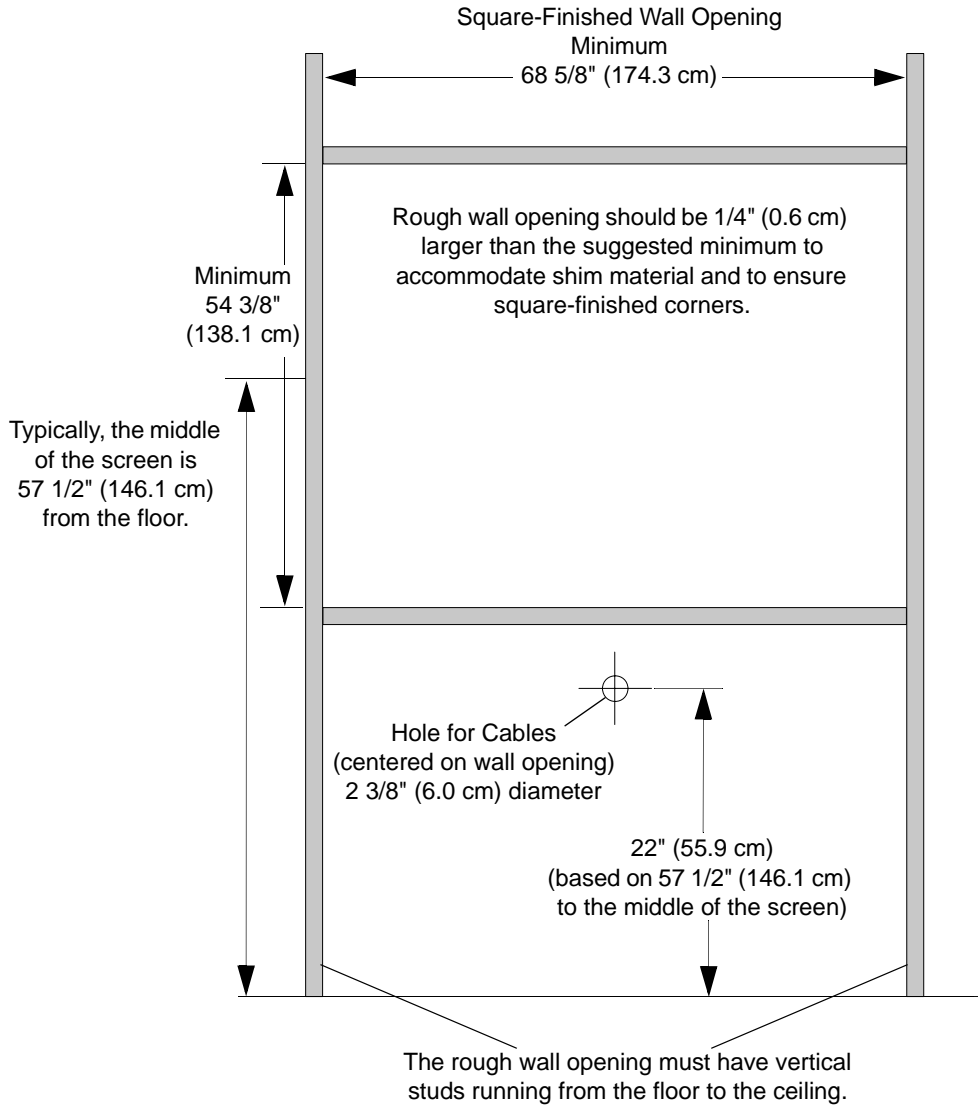

SMART Order Number

WRPSB 2976-DV

In-Wall *Rear Projection* SMART Board 1910 interactive whiteboard, mirror stand and NEC VT676 projector

Optional Accessories

01-00161

Replacement projector lamp and air filter for the NEC VT676 projector (NEC part No. VT75LP)

93-00360

Optional 20' (6.1 m) straight-through DB9F-to-DB9F serial cable. Must be ordered separately for systems that don't support USB connections.

SMART Technologies Inc.

1207 – 11 Avenue SW, Suite 300

Calgary, AB T3C 0M5

CANADA

Phone +1.403.245.0333

Toll Free 1.888.42.SMART (Canada/U.S.)

info@smarttech.com www.smarttech.com

