

Actalyst™ Interactive Digital Signage

Specifications – Model KLX342 for Select 42" Flat-Panel Displays

NOTE: For a complete list of supported flat-panel displays, visit www.smarttech.com/ActalystSpec.

Physical Specifications

| | |
|------------------------|---------------------------------------------------------------------------------------------------|
| Size | Landscape Orientation 46 1/4" W x 30 3/4" H x 2 3/8" D (117.5 cm x 78.1 cm x 6.0 cm) |
| Weight | 47 lb. (21.3 kg) |
| Shipping Size | 58" W x 46 1/2" H x 21" D (147.3 cm x 118.1 cm x 53.3 cm) |
| Shipping Weight | 110 lb. (50.0 kg) |

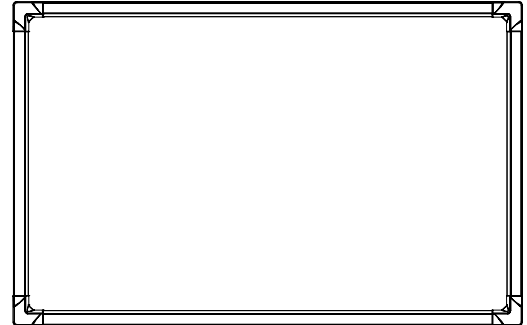

All dimensions +/- 1/8" (0.3 cm). All weights +/- 2 lb. (0.9 kg).

Standard Features

| | |
|-------------------------------|--------------------------------------------------------------------------------------------------------------------------------------------------------------------------------------------------------------------------------------------------------------------------------------------------------------------------------------------------------------------------------------------------------------------------------------------------------------------------------------------------------------------------------------------|
| Software | Actalyst™ interactive overlay touch driver software. Upgrades are available at http://www2.smarttech.com/st/en-US/Support/Downloads/default.htm . |
| Controller | You can mount the controller on the back of the interactive overlay with two included thumbscrews. A modular cable connects the interactive overlay to the controller, and the controller connects to a computer with the included 21' 6" (6.5 m) USB/serial converter cable. The DB9 serial connector connects to the controller and the USB connector connects to an available USB receptacle on the computer. |
| Mounting Brackets | Four mounting brackets secure the interactive overlay to the flat-panel display with eight No. 8-32 thumbscrews. |
| Front Surface Material | Hard-coated, anti-glare polyester that's designed for optimal light transmission. Chemical and scratch resistant. |
| Digitizing Technology | DViT™ (Digital Vision Touch) technology uses two digital cameras in the top two corners of the interactive overlay to track an object interacting with the display surface. |
| Power Requirements | Switching power supply, 100V–250V AC, 47 Hz–63 Hz, 12V DC 4.2A, 6' (1.8 m) power cord |
| Power Consumption | Power consumption is up to 40 W. |
| Compliance | CE, WEEE, RoHS (Europe), RoHS (China) |
| Warranty | Two-year limited equipment warranty |
| Installation Notes | You can install the interactive overlay on a flat-panel display that is securely mounted to a wall or floor stand. However, the wall mount or floor stand must be able to support a combined weight of 170 lb. (77.1 kg). Because of stability and mechanical fit issues, table stands are not recommended. You cannot attach speakers directly to the sides of a flat-panel display when an interactive overlay is installed. Do not install the Actalyst interactive overlay where it will be exposed to the weather or direct sunlight. |

Computer Requirements

| | |
|---------------------------|-------------------------------------------------------------------------------------------------------------------------------------------------------------------------------------------------------------------------|
| Windows® Computers | Pentium® II 450 MHz processor 128 MB of RAM (256 MB recommended) 60 MB of free hard disk space Windows 2000, Windows XP or Windows Vista™ operating system Internet Explorer® Internet browser 6.0 or later |
|---------------------------|-------------------------------------------------------------------------------------------------------------------------------------------------------------------------------------------------------------------------|

Specifications – Model KLX342 for Select 42" Flat-Panel Displays

Mac Computers

700 MHz processor (1 GHz or faster recommended)
97 MB of RAM (256 MB recommended)
75 MB of free hard disk space
Mac OS X version 10.4.x operating system software
Safari application program version 1.3.2 or later
SMART Board software version 9.7 supports both PowerPC® and Intel® processors (universal binary)

Linux® Computers

Pentium II 450 MHz processor
128 MB of RAM (256 MB recommended)
28 MB of free hard disk space
Linux kernel version 2.6 or later
X Window System™ version 11 release 6 (X11R6) or later (must support XRender, Xinerama™, XFixes, Xau and Xdmcp)
glibc 2.3.3 (gcc 3.4.2)
libstdc++6
GNOME™ 2.8.0+ or KDE® 3.3+ libraries (recommended)
SUSE™ 10, Red Hat® Enterprise Linux 4 WS, Debian® 3.1 (Sarge), Ubuntu® 6.06 LTS or Fedora™ Core 3+

Storage and Operating Specifications

Storage

-40°F to 95°F (-40°C to 35°C) with up to 95% humidity non-condensing

Operation

41°F to 95°F (5°C to 35°C) with up to 90% humidity non-condensing

Dimensions

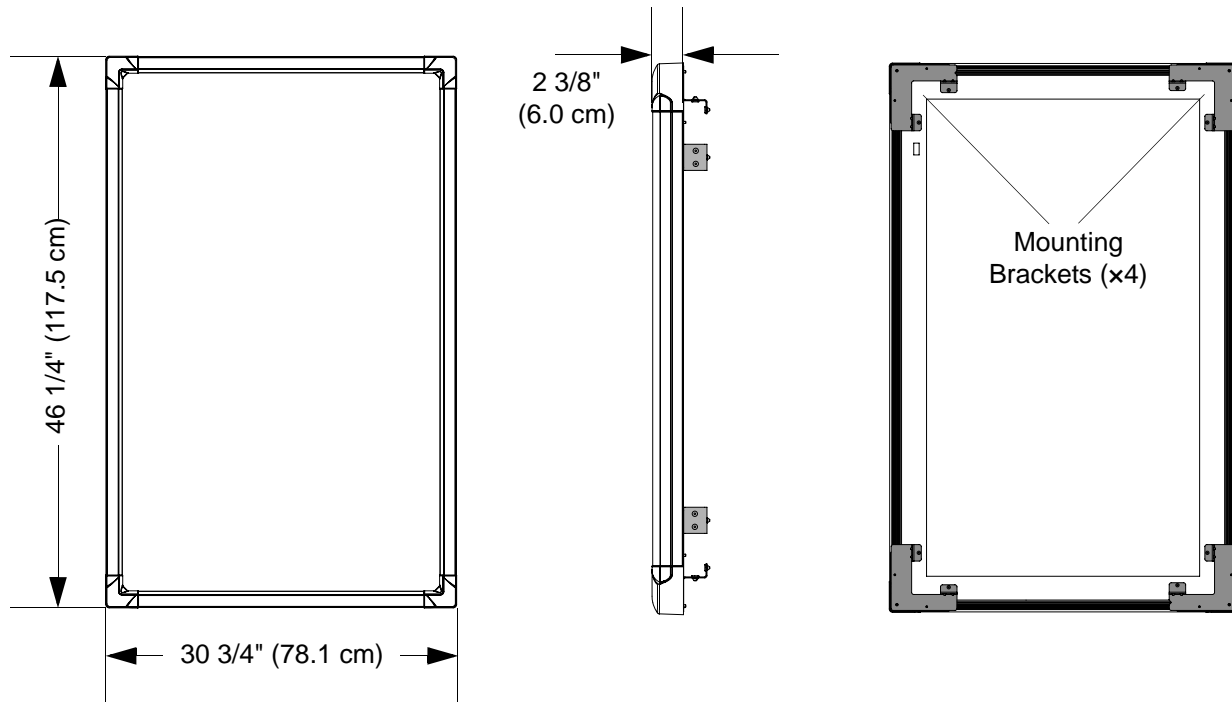

SMART Order Number

KLX342

Actalyst interactive overlay for select 42" flat-panel displays in landscape orientation

SMART Technologies
1207 – 11 Avenue SW, Suite 300
Calgary, AB T3C 0M5
CANADA

www.smarttech.com/support www.smarttech.com/contactsupport
Support +1.403.228-5940 or Toll Free 1.866.518.6791 (Canada/U.S.)

SMART
Technologies