

SMART Board™ Interactive Whiteboard

Specifications – Model 540

Physical Specifications

Size	SMART Board Interactive Whiteboard	40" W × 33" H × 5 3/4" D (101.6 cm × 83.8 cm × 14.6 cm)
	Active Screen Area	37 1/2" W × 28 1/8" H (95.3 cm × 71.4 cm)
		47" (119.4 cm) diagonal
	Shipping Carton	45" W × 37" H × 7" D (114.3 cm × 94.0 cm × 17.8 cm)
Weight	SMART Board Interactive Whiteboard	20 lb. 13 oz. (9.5 kg)
Shipping Weight	SMART Board Interactive Whiteboard and Carton	34 lb. (15.4 kg)

All dimensions +/- 1/8" (3.2 mm). All weights +/- 2 lb. (0.9 kg).

Standard Features

Software	SMART Board software and Notebook™ software. Free software upgrades are available at www.smarttech.com/support/software/index.asp .	
Pen Tray	Optical sensors in the pen tray detect when a pen or eraser is lifted from the tray. LEDs show the active tool.	
Pens and Eraser	Black, blue, red and green Whisper-tip™ pens and an eraser	
Resolution	Touch resolution is approximately 2000 × 2000	
Screen Surface	Extremely durable, hardcoat polyester finish that reduces reflection and glare. The optional OptiPro™ surface is specifically designed for use with high-lumens projectors and is not intended for use with dry-erase markers.	
Digitizing Technology	Two resistive sheets separated by an air gap	
Frame Finish	Textured, graphite-gray plastic surface	
Wall-Mount Bracket	Supports the interactive whiteboard when mounted to a wall	
Computer Connection	Unless otherwise specified, a 21'6" (6.6 m) SMART USB/Serial/Power adapter cable is included	
Power Requirements	Power is obtained from the computer directly through the SMART USB adapter cable for both Windows® and Macintosh computers. Power consumption is less than 5 watts.	
Certifications	CSA (Canada/U.S.)/CE	
Warranty	Two-year limited equipment warranty with an additional three years free of charge upon registration	

NOTE: A digital projector is *not* included with this model of SMART Board interactive whiteboard. To take advantage of all interactive features, you must integrate a digital projector.

Computer Requirements

Windows Operating Systems	Pentium® 150 MHz processor (450 MHz or faster recommended) 128 MB of RAM (256 MB recommended) Available powered USB or serial port Approximately 160 MB of free hard disk space for full installation Windows NT® 4.0 (SP6), Windows 98 operating system or later Microsoft Internet Explorer 6.0 or later Macromedia® Flash® player version 7.0.19 or later (recommended)
Requirements for SMART Video Player	Pentium 450 MHz processor (700 MHz or faster recommended) Windows 98 operating system or later. Does not run on the Windows NT operating system. Microsoft DirectX® 8.1 End-User Runtime or later
Macintosh Computers	400 MHz processor (800 MHz or faster recommended) 128 MB of RAM (256 MB recommended) Mac OS X version 10.1.5 or later (with Java™ version 1.3.1 update 1 or later) 50 MB of free hard disk space for minimum installation, 115 MB for full installation with Gallery collections Available powered USB port NOTE: SMART Board software is not compatible with versions 10.3.0, 10.3.1 or 10.3.2 of the Mac OS X operating system. To use the handwriting recognition feature, you must have Mac OS X version 10.3.3 or later.

Storage and Operating Specifications

Storage	-40°F to 95°F (-40°C to 35°C) with up to 80% humidity non-condensing
Operation	41°F to 95°F (5°C to 35°C) with up to 80% humidity non-condensing

SMART Order Number

SB540	47" (119.4 cm) diagonal SMART Board Interactive Whiteboard with SMART USB adapter cable
FS540	Optional floor stand
93-059-01	Optional 20' (6.1 m) straight-through DB9F-to-DB9F serial cable. Must be ordered separately for systems that don't support USB connections.

SMART Technologies Inc.
1207 – 11 Avenue SW, Suite 300
Calgary, AB T3C 0M5
CANADA
Phone +1.403.245.0333 Toll Free 1.888.42.SMART (Canada/U.S.)
info@smarttech.com www.smarttech.com



SMART Board™ Interactive Whiteboard

Specifications – Model 540

Wall Mounted

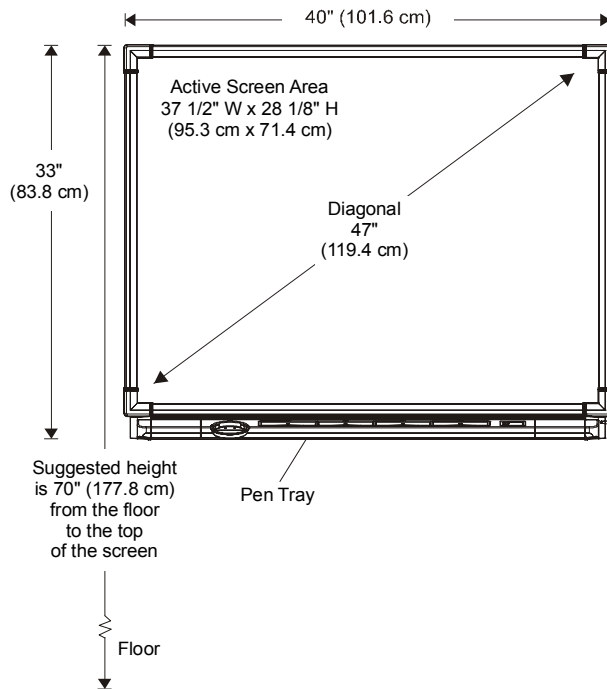

Floor Stand Mounted (optional)

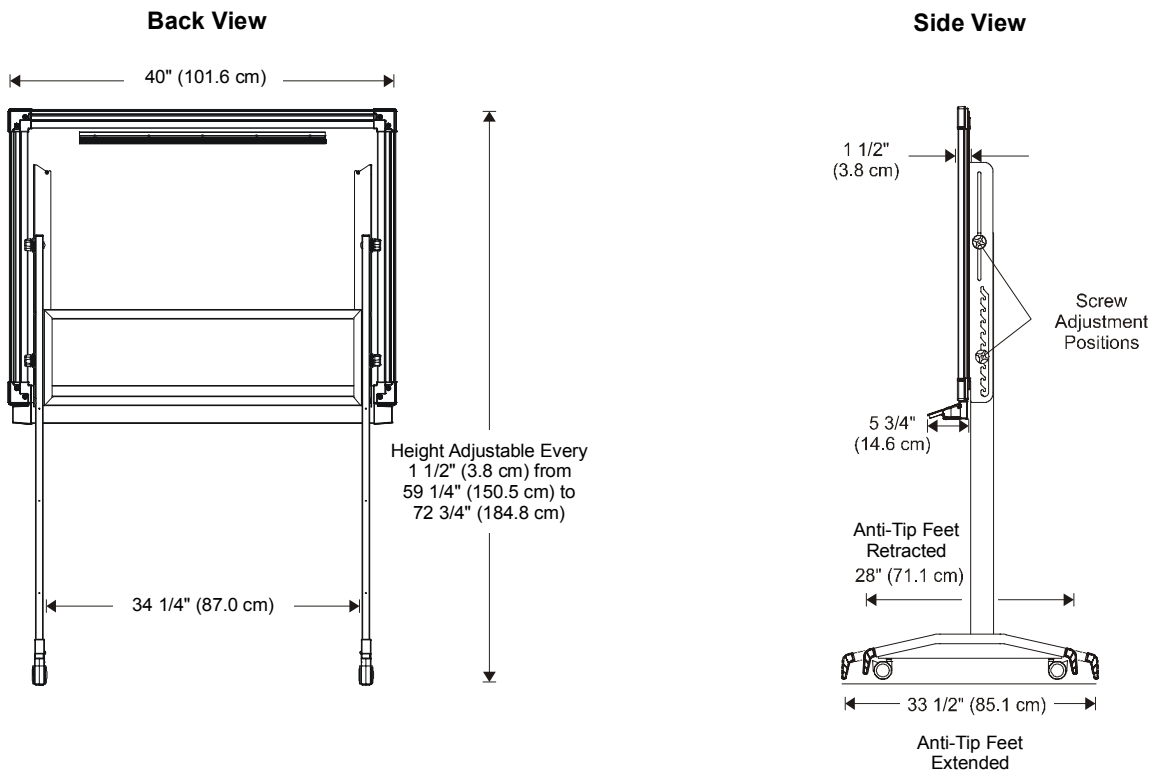

All dimensions +/- 1/8" (0.3 cm)

