

In-Wall *Rear Projection* SMART Board™ Interactive Whiteboard

Specifications – Model 1710

Physical Specifications

Size	57 3/8" W × 44" H × 2 5/8" D (145.8 cm × 111.8 cm × 6.7 cm)
Interactive Whiteboard	
Pen Tray with Keyboard Bracket	38 1/4" W × 9 5/8" H × 4 5/8" D (97.2 cm × 24.4 cm × 11.8 cm)
Active Screen Area	52 3/4" W × 39 5/8" H (134.0 cm × 100.7 cm) 66" (167.6 cm) diagonal
Installation Information	53 7/8" W × 43 1/4" H (136.8 cm × 110.0 cm) The interactive whiteboard must be mounted between two studs that run from floor to ceiling.
Weight	67 lb. (30.4 kg)
Shipping Weight	131 lb. (59.4 kg)
Shipping Size	71" W × 56" H × 21" D (180.3 cm × 142.2 cm × 53.3 cm)

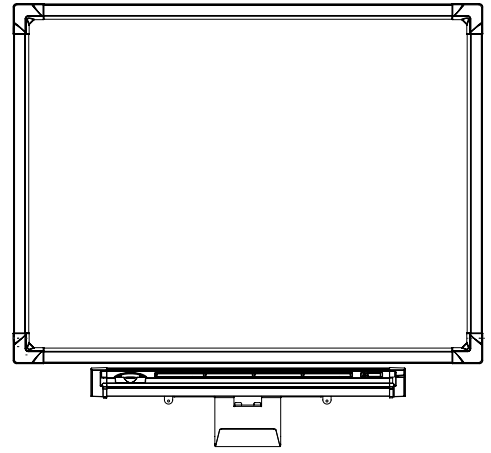

All dimensions +/- 1/8" (3.2 mm). All weights +/- 2 lb. (0.9 kg).

Standard Features

Software	SMART Notebook software included. See the SMART Notebook software specifications for a complete list of system requirements. Software upgrades are available at www2.smarttech.com/st/en-US/Support/SBS/ .
Pen Tray	Optical sensors in the pen tray detect when a pen or the eraser is lifted from the tray. LED indicators show the active tool. Includes four pens (black, blue, red and green) and one eraser.
Keyboard Bracket	Bracket attaches to the wall below the pen tray to hold the wireless keyboard and IR receiver
Wireless Keyboard	US English Windows® operating system with built-in trackball (all regions except Japan)
Resolution	Touch resolution approximately 2000 × 2000. Supports all projector resolutions up to 1600 × 1200.
SMART Super Screen	Bright image with uniform light distribution. Suitable for high ambient lighting, specifically meeting rooms or videoconferencing rooms
Screen Surface Material	Extremely durable, low-reflection (matte) finish reduces glare from overhead lights
Digitizing Technology	DViT™ (Digital Vision Touch) technology uses digital cameras to track an object interacting with the display surface
Projector	A projector is <i>not</i> included with this model of SMART Board interactive whiteboard. To take advantage of all interactive features, you must integrate a projector.
Computer Connection	A 21' 6" (6.6 m) SMART USB adapter cable is included
Power Supply	A switching power supply, 100V–250V AC, 47 Hz–63 Hz, 12V DC 4.2A, with a 6' (1.8 m) country-specific power cord
Power Requirements	Power consumption is approximately 50 watts
Warranty	Two-year limited equipment warranty

Storage and Operating Specifications

Storage	-40°F to 95°F (-40°C to 35°C) with up to 95% humidity non-condensing
Operation	41°F to 95°F (5°C to 35°C) with up to 90% humidity non-condensing

Front and Side Views

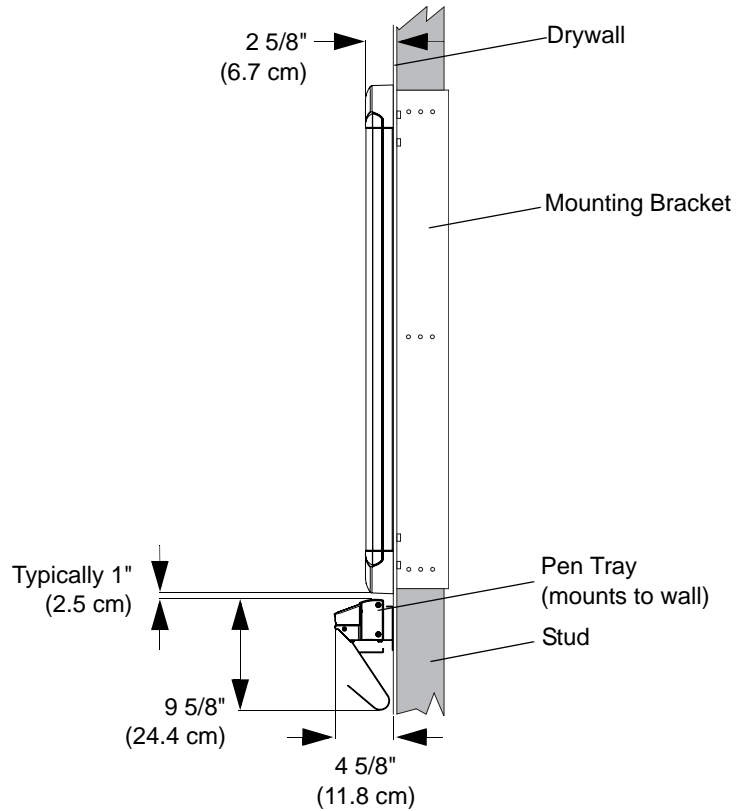
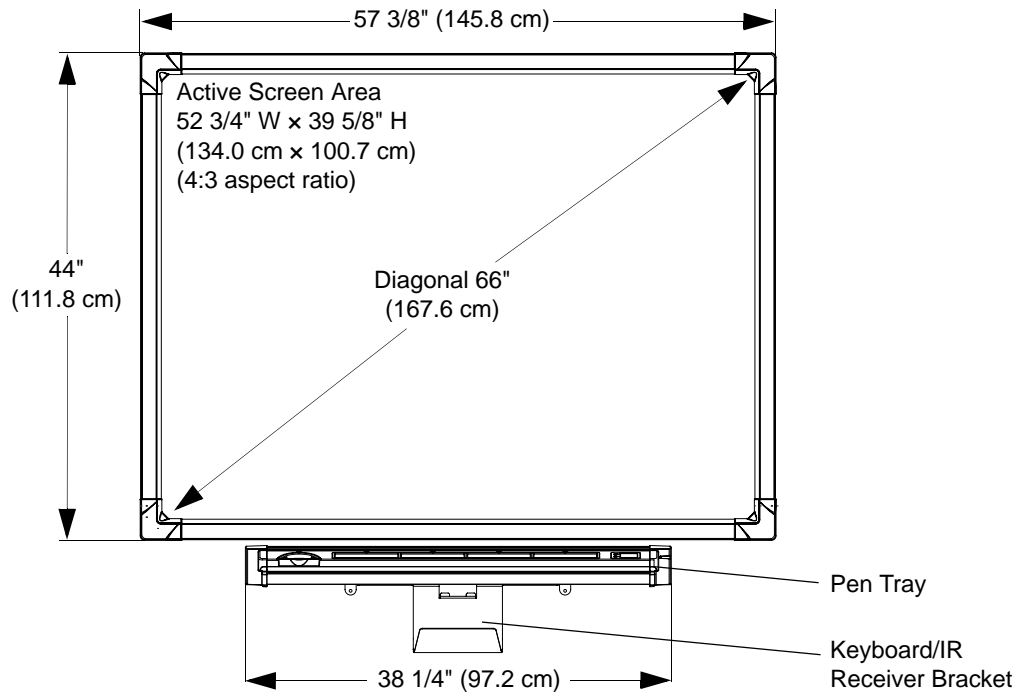

Wall Opening

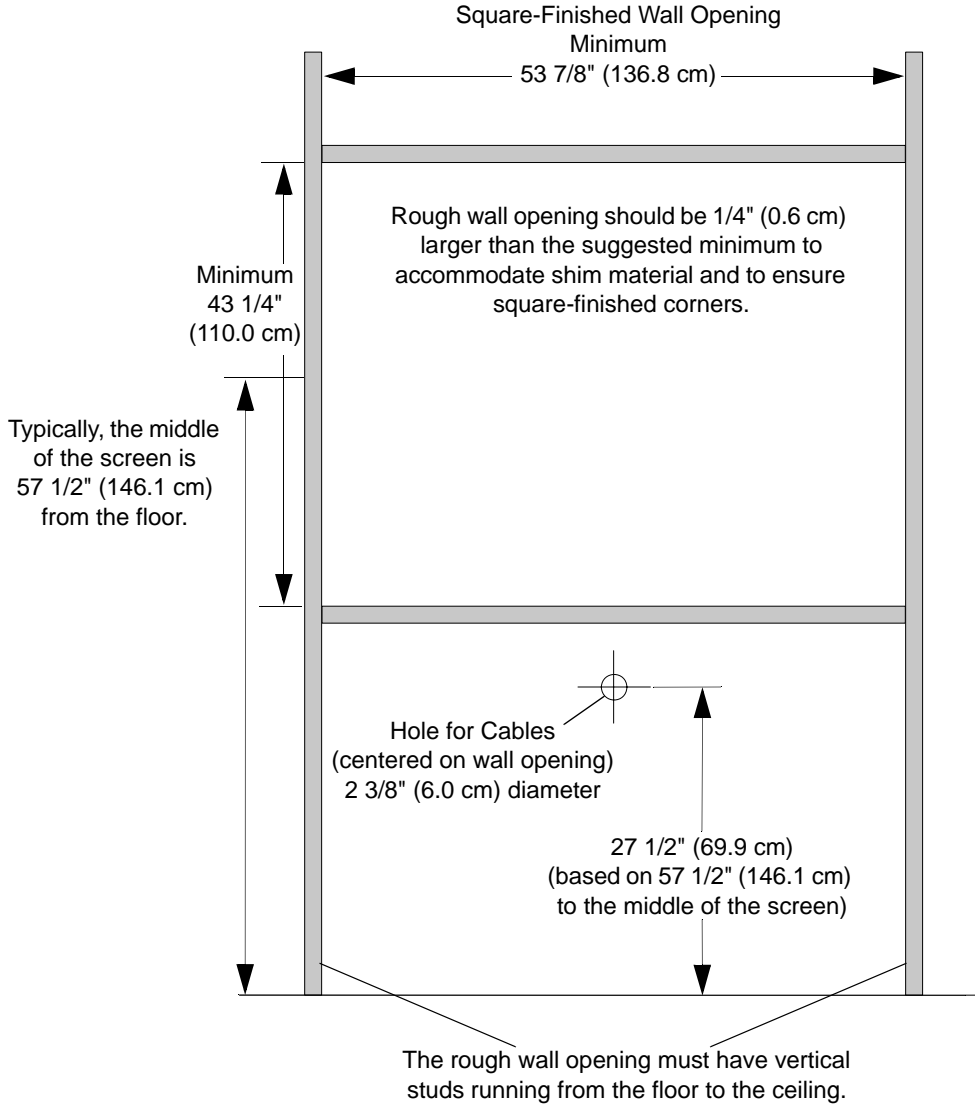

SMART Order Number

WRPSB 1710-DV

In-Wall *Rear Projection* SMART Board 1710 interactive whiteboard

93-00360

Optional 20' (6.1 m) straight-through DB9F-to-DB9F serial cable. Must be ordered separately for systems that don't support USB connections.