

Actalyst™ Interactive Digital Signage

Specifications – Model KLX342b for Select 42" Flat-Panel Displays

NOTE: For a complete list of supported flat-panel displays, visit www.smarttech.com/ActalystSpec.

Physical Specifications

Size	Landscape Orientation 46 1/4" W x 30 3/4" H x 2 3/8" D (117.5 cm x 78.1 cm x 6.0 cm)
Weight	47 lb. (21.3 kg)
Shipping Size	58" W x 46 1/2" H x 21" D (147.3 cm x 118.1 cm x 53.3 cm)
Shipping Weight	110 lb. (50.0 kg)

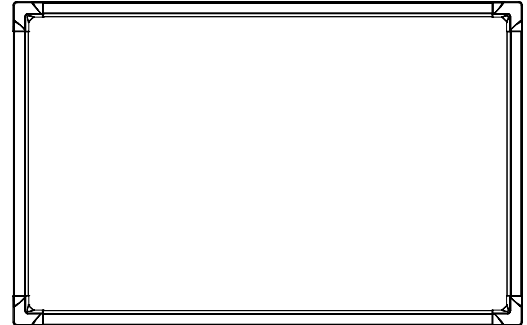

All dimensions +/- 1/8" (0.3 cm). All weights +/- 2 lb. (0.9 kg).

Standard Feature

Software	Actalyst™ interactive overlay touch driver software. Upgrades are available at http://www2.smarttech.com/st/en-US/Support/Downloads/default.htm .
Controller	You can mount the controller on the back of the interactive overlay with two included thumbscrews. A modular cable connects the interactive overlay to the controller, and the controller connects to a computer with the included 21' 6" (6.5 m) USB/serial converter cable. The DB9 serial connector connects to the controller and the USB connector connects to an available USB receptacle on the computer.
Mounting Brackets	Four mounting brackets secure the interactive overlay to the flat-panel display with eight No. 8-32 thumbscrews.
Front Surface Material	Hard-coated, anti-glare polyester that's designed for optimal light transmission. Chemical and scratch resistant.
Digitizing Technology	DViT™ (Digital Vision Touch) technology uses two digital cameras in the top two corners of the interactive overlay to track an object interacting with the display surface.
Power Requirements	Switching power supply, 100V–250V AC, 47 Hz–63 Hz, 12V DC 4.2A, 6' (1.8 m) power cord
Power Consumption	Power consumption is up to 40 W.
Compliance	CE, WEEE, RoHS (Europe), RoHS (China)
Warranty	Two-year limited equipment warranty
Installation Notes	You can install the interactive overlay on a flat-panel display that is securely mounted to a wall or floor stand. However, the wall mount or floor stand must be able to support a combined weight of 170 lb. (77.1 kg). Because of stability and mechanical fit issues, table stands are not recommended. You cannot attach speakers directly to the sides of a flat-panel display when an interactive overlay is installed. Do not install the Actalyst interactive overlay where it will be exposed to the weather or direct sunlight.

Computer Requirements

Windows® Computers	Pentium® II 450 MHz processor 128 MB of RAM (256 MB recommended) 60 MB of free hard disk space Windows 2000, Windows XP or Windows Vista™ operating system Internet Explorer® Internet browser 6.0 or later
---------------------------	---

Specifications – Model KLX342b for Select 42" Flat-Panel Displays

Mac Computers	700 MHz processor (1 GHz or faster recommended) 97 MB of RAM (256 MB recommended) 75 MB of free hard disk space Mac OS X version 10.4.x operating system software Safari application program version 1.3.2 or later SMART Board software version 9.7 supports both PowerPC® and Intel® processors (universal binary)
Linux® Computers	Pentium II 450 MHz processor 128 MB of RAM (256 MB recommended) 28 MB of free hard disk space Linux kernel version 2.6 or later X Window System™ version 11 release 6 (X11R6) or later (must support XRender, Xinerama™, XFixes, Xau and Xdmcp) glibc 2.3.3 (gcc 3.4.2) libstdc++6 GNOME™ 2.8.0+ or KDE® 3.3+ libraries (recommended) SUSE™ 10, Red Hat® Enterprise Linux 4 WS, Debian® 3.1 (Sarge), Ubuntu® 6.06 LTS or Fedora™ Core 3+

Storage and Operating Specifications

Storage	-40°F to 95°F (-40°C to 35°C) with up to 95% humidity non-condensing
Operation	41°F to 95°F (5°C to 35°C) with up to 90% humidity non-condensing

Specifications – Model KLX342b for Select 42" Flat-Panel Displays

Dimensions

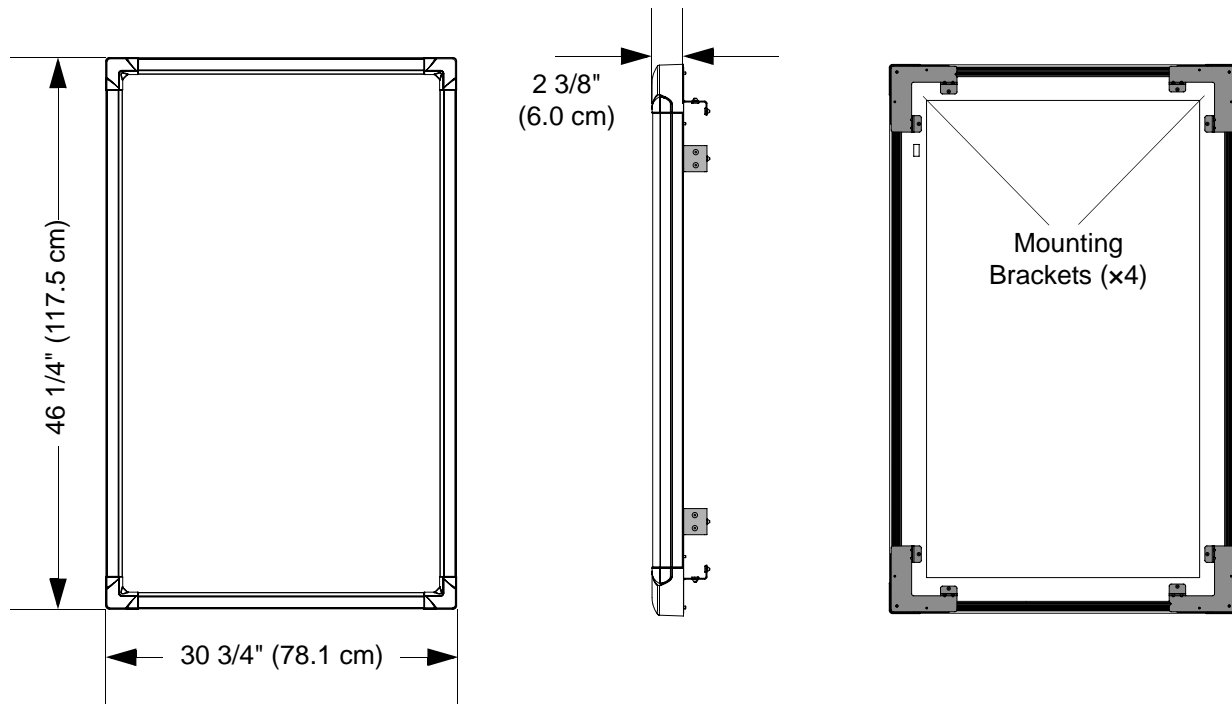

SMART Order Number

KLX342b

Actalyst interactive overlay for select 42" flat-panel displays in landscape orientation

SMART Technologies
1207 – 11 Avenue SW, Suite 300
Calgary, AB T3C 0M5
CANADA

SMART
Technologies

www.smarttech.com/support www.smarttech.com/contactsupport
Support +1.403.228-5940 or Toll Free 1.866.518.6791 (Canada/U.S.)

© 2004–2007 SMART Technologies ULC. All rights reserved. Actalyst, DVIT, smarttech and the SMART logo are trademarks or registered trademarks of SMART Technologies ULC in the U.S. and/or other countries. Windows and Windows Vista are either registered trademarks or trademarks of Microsoft Corporation in the U.S. and/or other countries. All other third-party product and company names may be trademarks of their respective owners. U.S. Patents Nos. 5,448,263; 6,141,000; 6,337,681; 6,747,636; 6,803,906; 6,919,880; 6,947,032; 6,954,197; 7,184,030 and 7,236,162. Canadian Patent No. 2,058,219. European Patent No. EP 1,297,488. Other U.S., Canadian and foreign patents pending. Specifications are subject to change without notice. 11/2007.